



WELDING TECHNOLOGIES

ARVAL 5 - MC TYPE

Balancers from 15 to 55kg



■ MC type (Medium Casted)

Designation	ARO reference	Load range (kg)	Stroke (m)
MC15	YZKA723501	15 - 25	2
MC25	YZKA723502	25 - 35	2
MC35	YZKA723503	35 - 45	2
MC45	YZKA723504	45 - 55	2

■ MC type (Medium Casted) with ratchet lock

Designation	ARO reference	Load range (kg)	Stroke (m)
MC15 (ratchet lock)	YZKA723601	15 - 25	2
MC25 (ratchet lock)	YZKA723602	25 - 35	2
MC35 (ratchet lock)	YZKA723603	35 - 45	2
MC45 (ratchet lock)	YZKA723604	45 - 55	2

■ Options

- Swivel (only available for MC range without ratchet lock)

■ Accessories

- Stainless steel cable



Quality without compromise

■ Main features

- Cast aluminium casing and cover
- Gradual adjustment of the effective load by endless screw
- Tapered drum (high strength aluminium)
- Spring encapsulated (safety)
- Insulated cable
- Safety chain

■ Main applications

- Welding guns (S serie guns)
- Welding cabinets (MC range with ratchet lock)
- Small tools

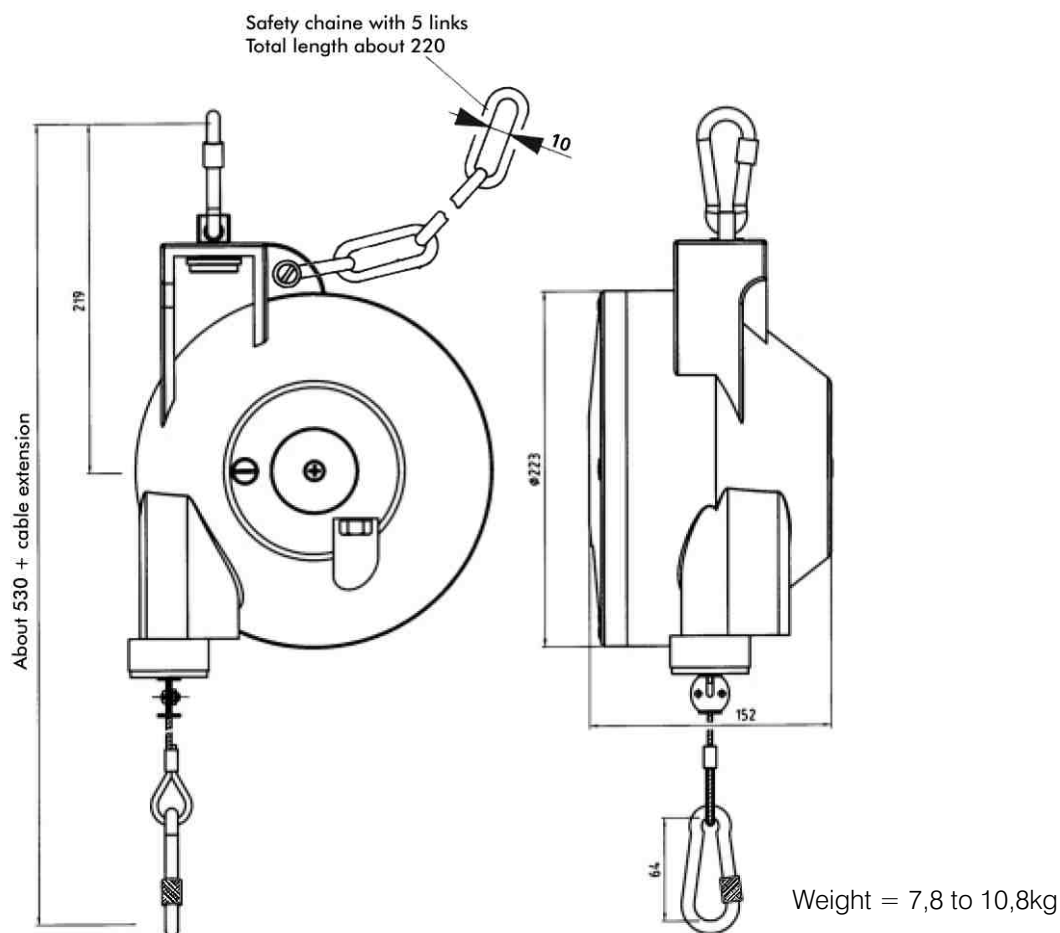

ROBOTIC WELDING
MANUAL WELDING
STATIONARY WELDING
MOBILE WELDING
LASER WELDING
ARO CONTROLS
ARO SYSTEMS
ARO®Rebuild
PARTS & COMPONENTS

ARO Welding Technologies SAS

1, Avenue de Tours - BP 40161,
72500 Château du Loir,
FRANCE
T +33 (0)2 43 44 74 00
F +33 (0)2 43 44 74 01
E france@arotechnologies.com



WELDING TECHNOLOGIES

www.arotechnologies.com

A Langley Holdings Company

C801GB - 0311